



**48393383**  
Edition 01  
April 2012

# **Air Starters for Internal Combustion Engines**

**SS100 Series**

---

## **Maintenance Information**



**Save These Instructions**

**IR** *Ingersoll Rand*

## General Instructions

1. Reference Parts Information Manual for item number call outs.
2. Do not disassemble the tool any further than necessary to replace or repair damaged parts.
3. Whenever grasping a tool or part in a vise, always use leather covered or copper covered vise jaws to protect surface of the part and help prevent distortion.
4. Ensure all parts are clean and free of debris or damage before assembly. Replace any damaged parts with **genuine Ingersoll Rand replacements**.
5. All O-rings shall be free of cuts and lubricated upon installation unless otherwise noted.
6. Always wear eye protection when operating or performing maintenance on this tool.
7. Always turn off the air or natural gas supply and disconnect the air or natural gas supply before installing or removing and before performing any maintenance on this tool.

## Motor removal

1. Mark alignment between intermediate housing (16) and motor housing (15) and between motor cover (1) and motor housing (15) to aid in reassembly.
2. Place starter with pinion (33) facing down.
3. Remove 4 screws holding motor cover (1) to motor housing (15).
4. Remove motor cover (1), o-ring (5), and motor housing oring (14).
5. While keeping motor dowel (13) in place, place starter with drive pinion (33) facing up.
6. Remove 4 screws holding intermediate housing (16) to motor housing (15).
7. Remove intermediate housing assembly.
8. Remove motor housing o-ring (14).
9. Carefully lift motor housing (15) from motor assembly.

## Motor disassembly

1. In a press, place motor assembly with rotor (11) pinion up while supporting cylinder (9) along edge of one exhaust passage. See Dwg. 48404032 SH1.

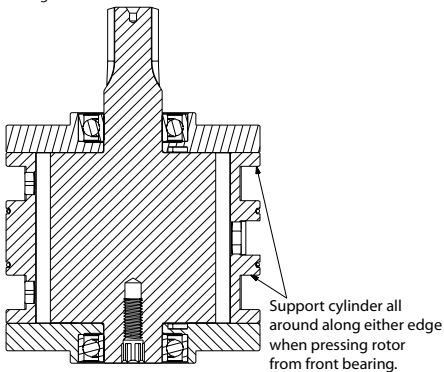

(Dwg. 48404032 SH1)

2. Press rotor (11) from bearing (6).
3. Remove front end plate (12), bearing (6), cylinder (9) and vanes (10).
4. Press rotor (11) from rear bearing (6).
5. Remove bearings from end plates.

## Motor assembly and Installation

1. Soak vanes (10) in **Ingersoll Rand #10** air tool oil for 2 hours prior to assembly.

2. In a press, place rotor (11) with pinion end down supporting the body of the rotor. Place rear end plate (7) over rotor (11) and with 0.003" thick shims between rotor and rear endplate, fully press motor bearing (6) onto rotor using bearing punch S5100-TL1. See Dwg. 48404032 SH2 and 48404032 SH3.

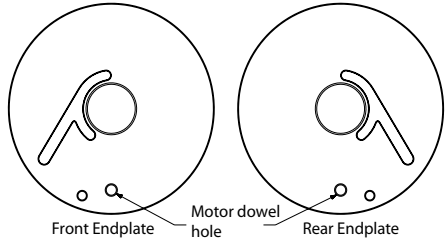

(Dwg. 48404032 SH2)

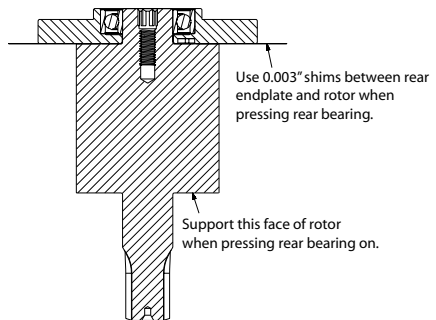

(Dwg. 48404032 SH3)

3. Remove shims.
4. Place motor housing (15) over rotor (11) and rear endplate (7) assembly in the proper orientation as previously marked. Intermediate housing mark shall be on pinion side of rotor. Motor dowel hole in rear end plate shall be on the inlet side of the motor housing.
5. Lubricate and install o-rings (8) onto cylinder (9).
6. Carefully place cylinder (9) in motor housing (15) over rotor (11). Holes in cylinder and rear end plate must be aligned for proper operation. Use motor dowel (13) or suitable tool to align cylinder and end plate holes. See Dwg. 48404032 SH4.

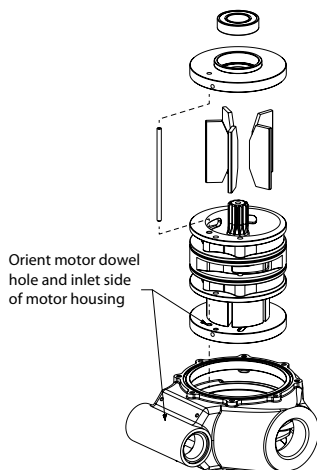

(Dwg. 48404032 SH4)

- Place vanes (10) in rotor slots. Add 6 cc [.2 oz] **Ingersoll Rand #10** air tool oil inside cylinder.
- Place front end plate (12) over rotor (11).
- While supporting rear boss of rotor (11), fully press motor bearing (6) onto rotor using bearing punch S5100-TL1.
- Apply light coat of **Ingersoll Rand #130** grease to rotor (11) pinion teeth.
- Place motor housing o-ring (14) in motor housing (15).
- Install intermediate housing assembly onto motor housing (15) in the proper orientation as previously marked. Tighten screws to 5-7 N-m [44-62 lb-in].
- Place assembly with drive pinion (33) down exposing rear of motor.
- Place motor housing o-ring (14) in motor housing (15).
- Install motor cover (1) with o-ring (5). O-ring must be installed with no lubrication. Incrementally tighten screws in a cross pattern until cover is fully seated. Tighten screws to 5-7 N-m [44-62 lb-in]

### Drive removal

- Mark orientation of flange (38) with drive housing (35).
- Remove 8 flange mounting screws (39) and remove flange (38).
- Remove 7 screws holding drive housing (35) to intermediate housing (16).
- Separate drive housing (35) from intermediate housing (16).
- Remove and discard gasket (34).
- Clean excess grease from housings.
- Remove drive pinion (33). See **Pinion Removal** section.
- Clean remaining grease from drive housing (35), intermediate housing (16) and gearing.

### Drive installation

- Apply **Ingersoll Rand #130** grease to drive shaft (25) splines. Loosely assemble drive components.
- Install drive pinion (33). See **Pinion Installation** section.
- Clean sealing surfaces and place new gasket (34) on intermediate housing (16).
- Apply **Ingersoll Rand #130** grease to ball (24) and place in hole in rear of drive shaft (25).
- Assemble drive housing (35) and drive assembly to intermediate housing (16).
- Tighten 7 screws in a cross pattern to 5-7 N-m [44-62 lb-in]
- Add 65cc **Ingersoll Rand #130** grease to gearing.

### Pinion removal

#### With fully assembled starter

- Extend drive pinion (33) by applying 60-90 psig air to one "I" port while plugging both "O" ports and the remaining "I" port. See Dwg. 48404032 SH5.

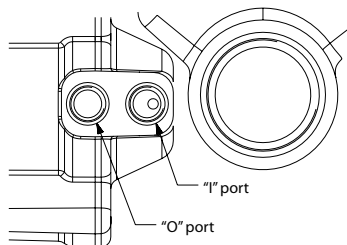

(Dwg. 48404032 SH5)

- Unseat pinion collar (31) and remove retaining ring (30) from drive shaft (25).
- Remove drive pinion (33), spring collar (28), and pinion spring (27).
- Remove air from "I" port.

#### With drive housing removed

- Secure drive housing (35), extend drive shaft (25) and depress drive pinion (33).
- Unseat pinion collar (31) and remove retaining ring (30) from drive shaft (25). Drive pinion (33) and drive shaft are under spring pressure. Exercise caution.

### Pinion installation

#### With fully assembled starter

- Place starter on a bench with drive shaft (25) facing up.
- Extend drive pinion (33) by applying 60-90 psig air to one "I" port while plugging both "O" ports and the remaining "I" port. See Dwg. 48404032 SH5.
- Apply light coat of **Ingersoll Rand #130** grease to drive shaft (25) straight splines.
- Place pinion spring (27), spring collar (28), drive pinion (33), and pinion collar (31) over the drive shaft (25).
- Install retaining ring (30) onto drive shaft (25).
- Remove air from "I" port.
- Seat retaining ring (30) in pinion collar (31).

#### With drive housing removed

- Place clutch assembly (29) in drive housing (35).
- Place return spring (26) and drive shaft (25) in clutch. Apply a light coat of **Ingersoll Rand #130** grease to the drive shaft helical and straight splines.
- In order, place pinion return spring (27), spring collar (28), and drive pinion (33) over drive shaft (25). Ensure spring collar is in the proper orientation.
- Place pinion collar (31) over drive shaft (25) in the proper orientation.
- Install retaining ring (30) on drive shaft (25).
- Place drive assembly with drive pinion (33) facing up while supporting the inner race of the rear bearing.
- Seat retaining ring (30) in pinion collar (31).

---

## Lubrication & Torque

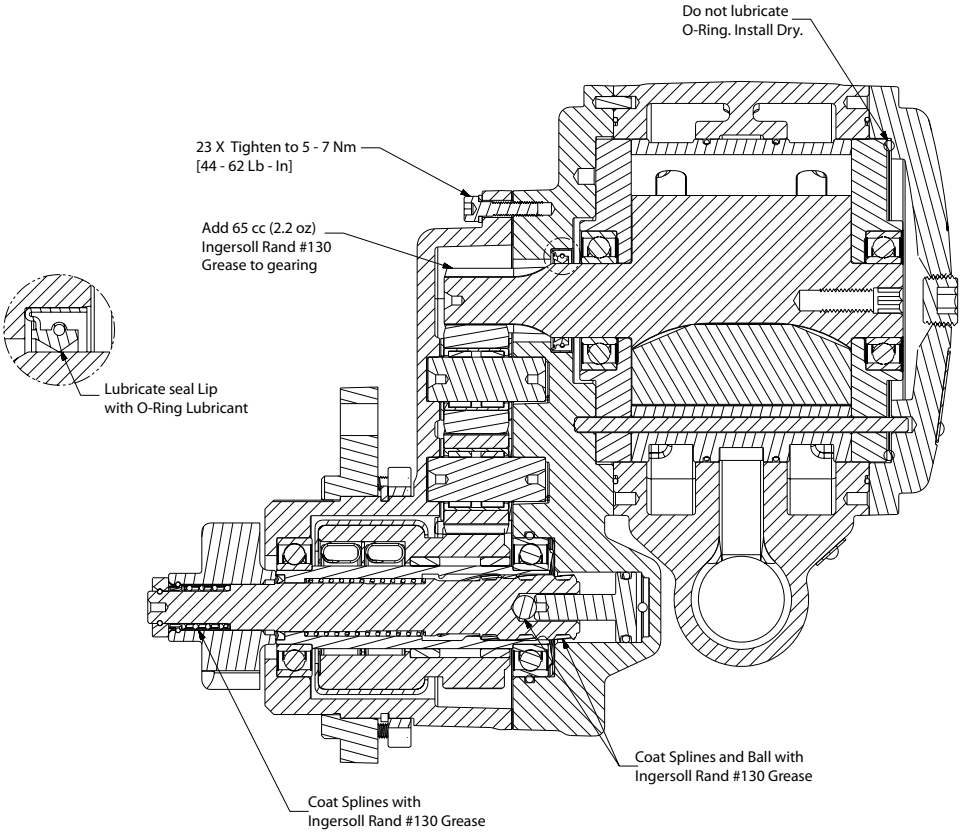

(Dwg. 48404032 SH6)

---

## Parts and Maintenance

When the life of the tool has expired, it is recommended that the tool be disassembled, degreased and parts be separated by material so that they can be recycled.

Tool repair and maintenance should only be carried out by an authorized Service Center.

Refer all communications to the nearest **Ingersoll Rand** Office or Distributor.

---

## Related Documentation

For additional information refer to:

Product Safety Information Manual 45558624

Product Information Manual 48393375

Parts Information Manual 48393391

Manuals can be downloaded from [www.ingersollrandproducts.com](http://www.ingersollrandproducts.com)

---

**Notes:**

**Notes:**

---

---

**Notes:**

[www.ingersollrandproducts.com](http://www.ingersollrandproducts.com)

© 2012 *Ingersoll Rand* Company

