



Air Starters

150BM Series

#1 Starter in the
oil and gas industries



For engine displacement of: Diesel-500 to 2000 CID (8 to 32 liters)
Carburated-1000 to 4000 CID (16 to 64 liters)

Features/Benefits

- 150BMG model sealed for use in gas or air applications
- Rugged 34 hp motor
- Multiple offset gear ratios: C = 2.69:1
E = 3.46:1
D = 3.94:1
- Backcap ports for injection lubricating

Versatile

- Inertia and pre-engaged drives available
- Left- and right-hand rotation available
- 4 inlet, 4 exhaust, and 18 drive housing orientations
- 90-150 psi (6.2-10.3 bars) operation
- Inline and offset designs



IR's genuine 150BMGE21RH-6R remanufactured starter is shown mounted on a Detroit Diesel 12V-71R.



The 150BMGE21RH-6 starters are shown mounted on a Cummins KTA14-M3 and KTA19-M4I.

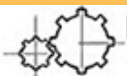

LOUZAMPINI & ASSOCIATES

Five Star Desoutter
★★★★★
Factory Authorized Dealer

Please Call **1-800-353-4676** for questions, pricing, or to order. We will be happy to assist you.

Air Starters

150BMG/150BMP Series DIMENSIONS

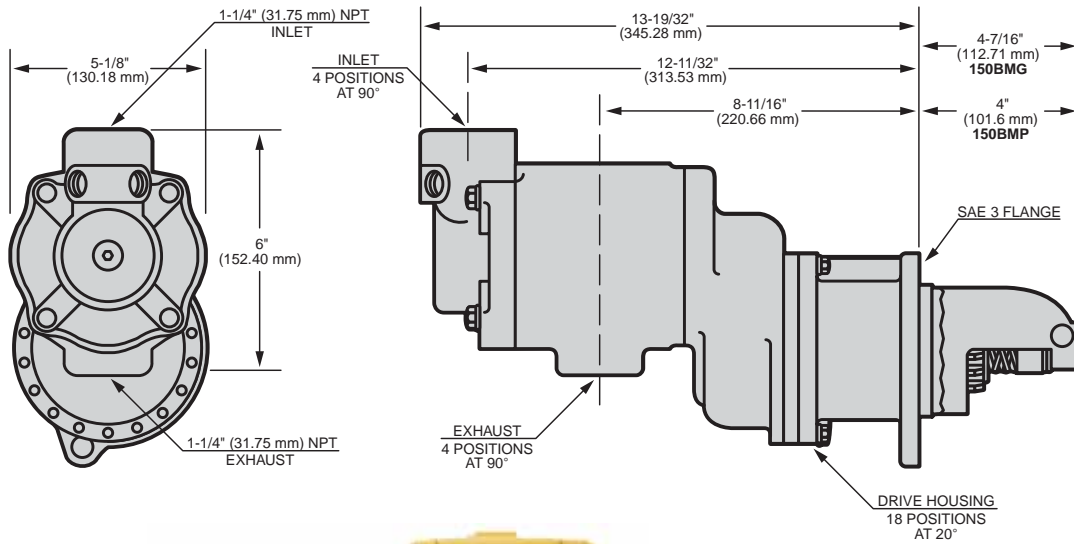

Weight lbs (kg)

150BMG	38 (17.2)
150BMP	40 (18.1)



150BMPD Series DIMENSIONS

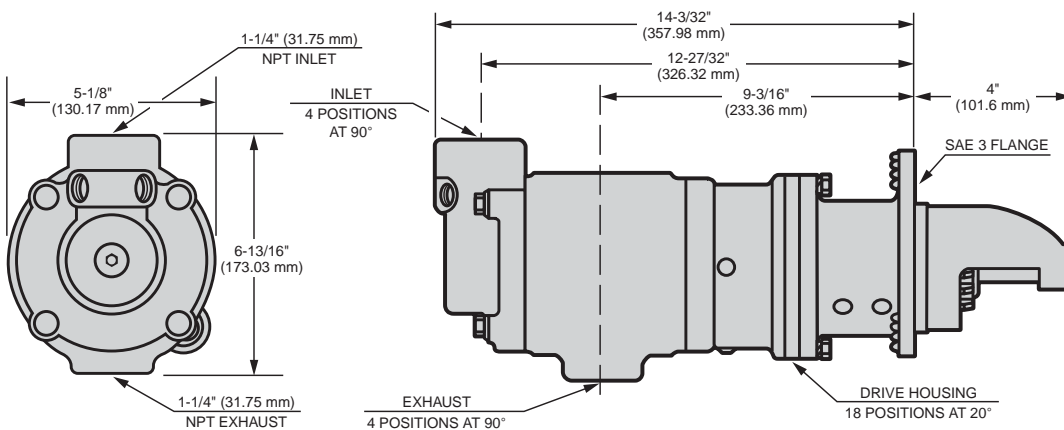

Weight lbs (kg)

150BMPD	40 (18.1)
---------	-----------

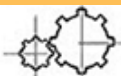

150BM Series

150BMGE/150BMPE Series Performance Information

Pressure PSI (bar)	Breakaway Torque ft-lb (Nm)	Speed @ Max HP RPM	Max Power HP (kw)	Flow @ Max HP SCFM (L/s)
90 (6.2)	100 (136)	1700	16 (12)	380 (179)
120 (8.3)	130 (176)	1900	24 (18)	500 (236)
150 (10.3)	155 (210)	2200	32 (24)	680 (321)

150BMPD Series Performance Information

Pressure PSI (bar)	Breakaway Torque ft-lb (Nm)	Speed @ Max HP RPM	Max Power HP (kw)	Flow @ Max HP SCFM (L/s)
90 (6.2)	110 (149)	1500	16 (12)	370 (175)
120 (8.3)	145 (196)	1700	24 (18)	500 (236)
150 (10.3)	175 (237)	1900	32 (24)	650 (307)

150BM Series Number of Starts per Tank







(Assuming 1-Second Crank Time @ 90 PSI)

Max Tank Pressure (psi)	300	16	25	33	41	49	57	66	74	20	Max Tank Pressure (bar)	
	270	14	21	29	36	43	50	57	64	18		
	240	12	18	25	31	37	43	49	55	16		
	210	10	15	20	26	31	36	41	46	14		
	180	8	12	16	20	25	29	33	37	12		
	150	6	9	12	15	18	21	25	28	10		
	120	4	6	8	10	12	14	16	18	8		
	90	2	3	4	5	6	7	8	9	6		
		40	60	80	100	120	140	160	180			
		151	227	302	378	454	529	605	680			
	Tank Size									Gallons Liters		

Air Starters

150BM Series Accessories

See catalog pages J-1 to J-18 for detailed Accessory information.

IR Part #	Description	Picture
1 150BM-A674	1 1/4" Muffler	
2 150BMP-1051B	1/4" 12 V Solenoid Valve	
3 150BMP-2451B	1/4" 24 V Solenoid Valve	
4 NL-24-8	In-Line Lubricator	
5 HDL2 (Stationary)	3/8" NPT Lubricator (1.3 cc)	
6 HDL3 (Transportation)	3/8" NPT Lubricator (0.4 cc)	
7 SMB-618	Push Button Valve	
8 SMB-G618	Push Button Valve For Natural Gas	

IR Part #	Description	Picture
9 SRV125T	1-1/4" Relay Valve For Vehicular Applications	
10 SRV150SS	1-1/2" Relay Valve For Stationary Gas Applications	
11 150BMP-1058	Gladhand	
12 150BMP-1064	1/8", 150 psi Pressure Gauge	
13 ST900-267-24	1-1/2" Strainer (300 Mesh)	
14 ST900-266-24	1-1/2" Strainer Element (300 Mesh)	
15 150BM-A735	Road Splash Deflector	

Red item numbers correspond to numbers in diagrams on page G-5.

150BM Series

150BMPE Typical Vehicular Installation

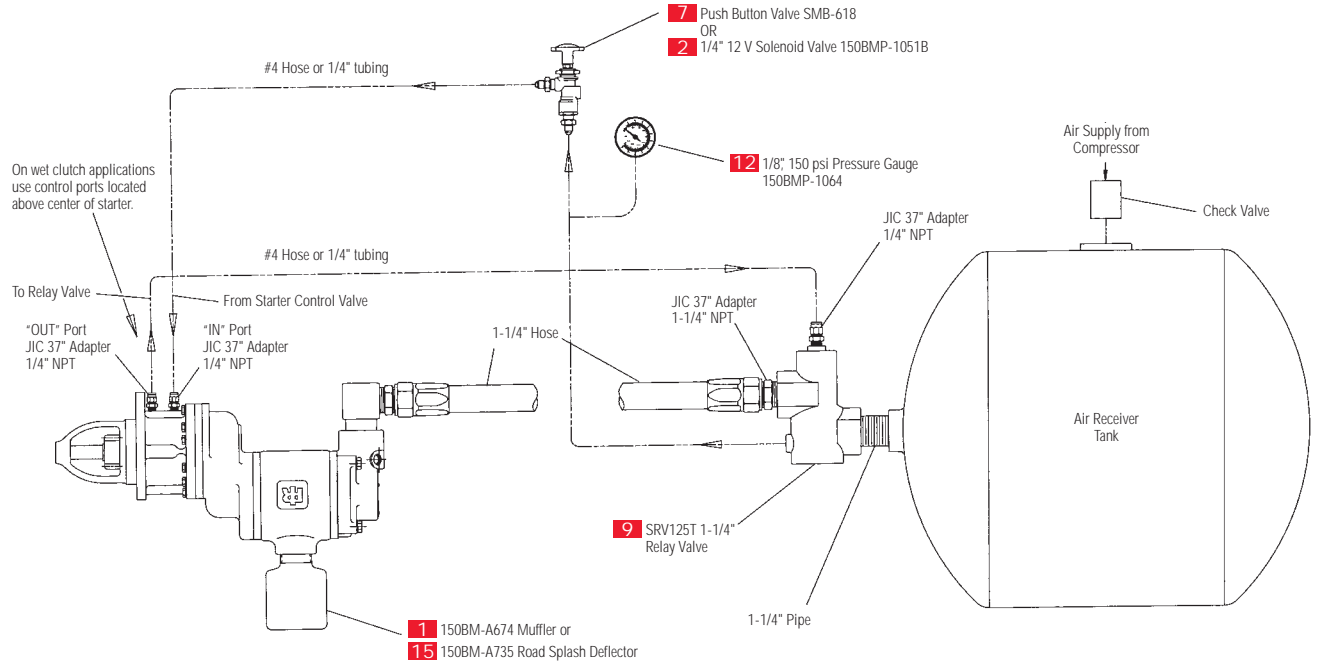

150BMG (Gas) Stationary Installation

For gas operation the exhaust outlet must be piped away to a safe location.

For natural gas operation, piped exhaust must be used and drive housing vent plug replaced with suitable hose which connects into piped exhaust system.

For air operation a muffler or splash guard deflector must be used.

NOTE: Use sealant on all pipe connections.

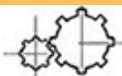
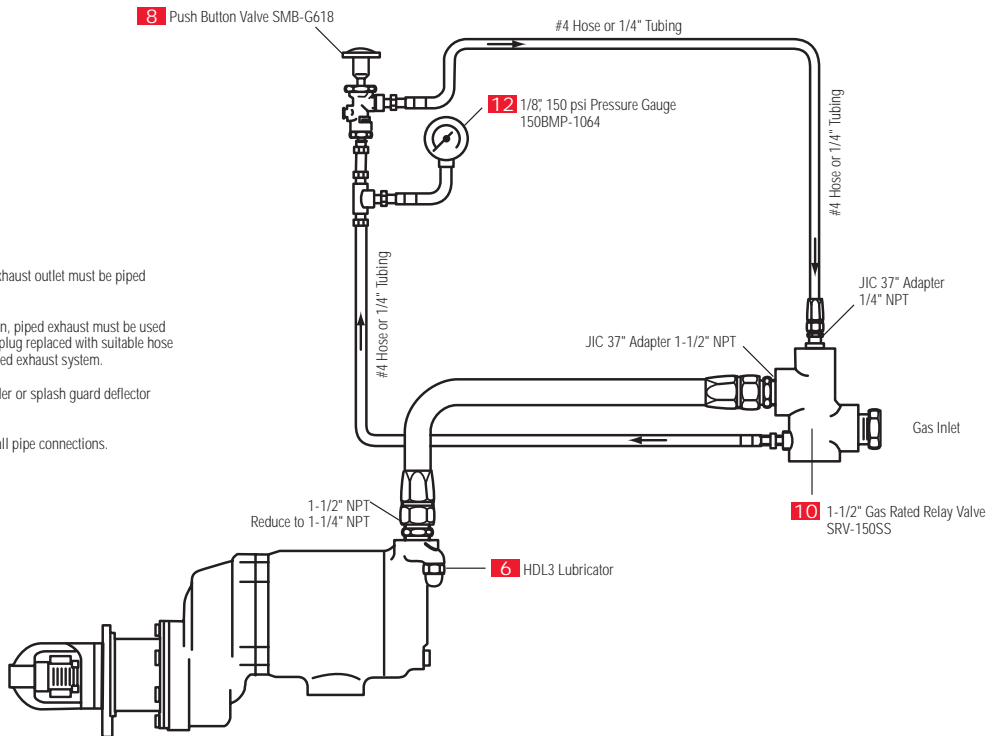

Air Starters

Bold Model Numbers indicate that a remanufactured model is available with the same part number (add an "R" to the number).

Most Obsolete Units ▶

150BM Crossover Model Numbers

150BM Available Units	150LF Crossovers	Obsolete Units	Obsolete Units	Obsolete Units	Obsolete Units
150BMGE21RH-6		101BMPC78RH-31	10BMB21RH-31		
150BMGE12RH-13		150BME12RH-13	150BME12RH-13	10BMB12RH-13	9BMA43RH-13
150BMGE21LH-11	150LFGE21LH11-000	150BME21LH-11	150BME21LH-11	10BMB21LH-11	9BMB31LH-11
150BMGE21LH-11	150LFGE21LH11-020	150BMGE21LH-11	150BMGE21LH-11	10BMB22LH-8	9BMA32LH-8
150BMGE21LH-32					
150BMGE21RH-6	150LFE21RH6-020	150BME21RH-6	150BME21RH-6	10BMB21RH-6	9BMA331RH-6
150BMGE21RH6-22R	150LFGE21RH6-000	150BME21RH-17	150BME21RH-17		
150BMGE22RH-5	150LFGE22RH5-020	150BME22RH-5	150BME22RH-5		
150BMGE22RH5-10D		150BMGE22RH-5	150BMGE22RH-5	10BMB12RH-13	9BMA43RH-13
150BMPD88L54-020					
150BMPD88R54-020		150BMPD88R-46	150BMPD89RH-46	150BMPAC03R85	
150BMPE81R15-00N	150LFPE81R15-020				
150BMPD88L54-11A		150BMPD89LH-50	150BMPD89LH-50	101BMPC78LH-11	
150BMPE88L54-12E		150BMPE88L-11	15BMPE78LH-11		
150BMPE88L54-13E		150BMPE88L-11	150BMPE83LH-11	10BMB21LH-11	9BMB31LH-11
150BMPE88L54-200	150LFPE88L54-000				
150BMPE88L54-20N					
150BMPE88L54-22N					
150BMPE88L54-33A					
150BMPE88L54-33C					
150BMPE88R51-200	150LFPE88R51-020				
150BMPE88R53-000		150BMPE88R-53	150BMPE78RH-53	101BMPC78RH-38	
150BMPE88R53-020	150LFPE88R53-020	150BMPE88R-53	150BMPE78RH-5	10BMB22RH-5	9BMA32RH-5
150BMPE88R53-12F					
150BMPE88R53-200					
150BMPE88R53-300					
150BMPE88R54-000	150LFPE88R54-000	150BMPE88R-44	150BMPE78RH-44	101BMPB78RH-44	
150BMPE88R54-00N	150LFPE88R54-00N	150BMPE88R-54	150BMPE78RH-54		
150BMPE88R54-02E	150LFPE88R54-02E		150BMPE78RH-6	101BMPC78RH-6	
150BMPE88R54-12C					
150BMPE88R54-12D	150LFPE88R54-12D				
150BMPE88R54-12E	150LFPE88R54-12E				
150BMPE88R54-200	150LFPE88R54-200				
150BMPE88R54-20E					
150BMPE88R54-220					
150BMPE88R54-22E					
150BMPE88R54-300	150LFPE88R54-300				
150BMPE88R54-32P					

150BM SERIES MODEL CODING

150 BMG E 21 RH 6 0 2 F

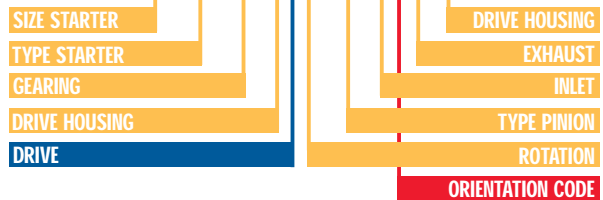

150BM Series

This chart is a condensed list of engines that can be cranked with an IR starter. For a complete list, please contact IR.

150BM Series Engine Selection Guide

Manufacturer	Engine	CID	Liter	CYL	Type	Vane Starter
CATERPILLAR	3126	439	7.2	6	Diesel	150BMPE81R15
	3176	629	10.3	8	Diesel	150BMPE88R54
	3406	893	14.6	6	Diesel	150BMPE88R54
	3408	1099	18	8	Diesel	150BMPE88R54
	D-334	638	10.5	6	Diesel	150BMPE88R53
	D-336	700	11.5	8	Diesel	150BMPE88R53
	D-343	893	14.6	6	Diesel	150BMPE88R54
	D-346	1191	19.5	8	Diesel	150BMPE88R54
	G-342	1246	20.4	6	Nat. Gas	150BMPE88R54
CES-AJAX	DP125	2205	36.1	1	Nat. Gas	150BMGE21LH-11
	DP165	2826	46.3	1	Nat. Gas	150BMGE21LH-11
	DPC180	2826	46.3	1	Nat. Gas	150BMGE21LH-11
	DPC60	850	14	1	Nat. Gas	150BMGE21LH-11
CLIMAX	K67	1616	26.5	6	Gas	150BMPE88R53
	K75	1855	30.4	6	Gas	150BMPE88R53
	R165	1238	20.3	6	Gas	150BMPE88R53
CONTINENTAL	R602	602	9.9	6	Gas	150BMPE88R53
	R6513	513	8.4	6	Gas	150BMPE88R53
	U6501	501	8.2	6	Gas	150BMPE88R53
CUMMINS	ISC	506	8.3	6	Diesel	150BMPE88R53
	ISL	549	9	6	Diesel	150BMPE88R53
	N-14 SERIES	855	14	6	Diesel	150BMPE88R54
	N-855 SERIES	855	14	6	Diesel	150BMPE88R54
	ISM	659	10.8	6	Diesel	150BMPE88R54
	ISX	915	15	6	Diesel	150BMPE88R54
DETROIT DIESEL	6V-71	426	7	6	Diesel	150BMGE21RH6
	6V-92	552	9	6	Diesel	150BMGE21RH6
	Series 50	519	8.5	4	Diesel	150BMPE88R54
	Series 60	778	12.7	6	Diesel	150BMPE88R54
EMD GM	12-645	7740	126.8	12	Diesel	2-150BMPD88R54
	12-710	8520	139.6	12	Diesel	2-150BMPD88R54
	16-645	10320	169.1	16	Diesel	2-150BMPD88R54
	16-710	11360	186.2	16	Diesel	2-150BMPD88R54
	20-645	12900	211.4	20	Diesel	2-150BMPD88R54
	20-710	14200	232.7	20	Diesel	2-150BMPD88R54
	8-645	5160	84.6	8	Diesel	150BMPD88R54
	8-710	5680	93.1	8	Diesel	150BMPD88R54
WAUKESHA	145GZ	817	13.4	6	Nat. Gas	150BMGE22RH5
	6GAK	784	12.8	6	Nat. Gas	150BMGE22RH5
	6WAK	1197	19.6	6	Nat. Gas	150BMGE21RH6
	F1197G	1197	19.6	6	Nat. Gas	150BMGE21RH6
	F119G	1197	19.6	6	Nat. Gas	150BMGE21RH-6
	H1077G	1077	17.6	8	Nat. Gas	150BMGE21RH6
	H24L	1462	24	8	Nat. Gas	150BMGE21RH6
	H867D	866	14.2	8	Diesel	150BMPE88R53
WHITE ENGINES	DFXD	855	14	6	Diesel	150BMPE88R54
	DFXE	895	14.7	6	Diesel	150BMPE88R54



150BM Series Air Starters

150BM Series Genuine Ingersoll-Rand Replacement Kits

Tune Up Kit Part Number	Description
150BM-TK2	150BM Products
150LF-TK2	150LF Products (uses 150LF-42 vanes)
150LF-TK1	150 Motor Gasket Kit for all vane motor 150 products
150BMPD-TK1	150BMPD Products

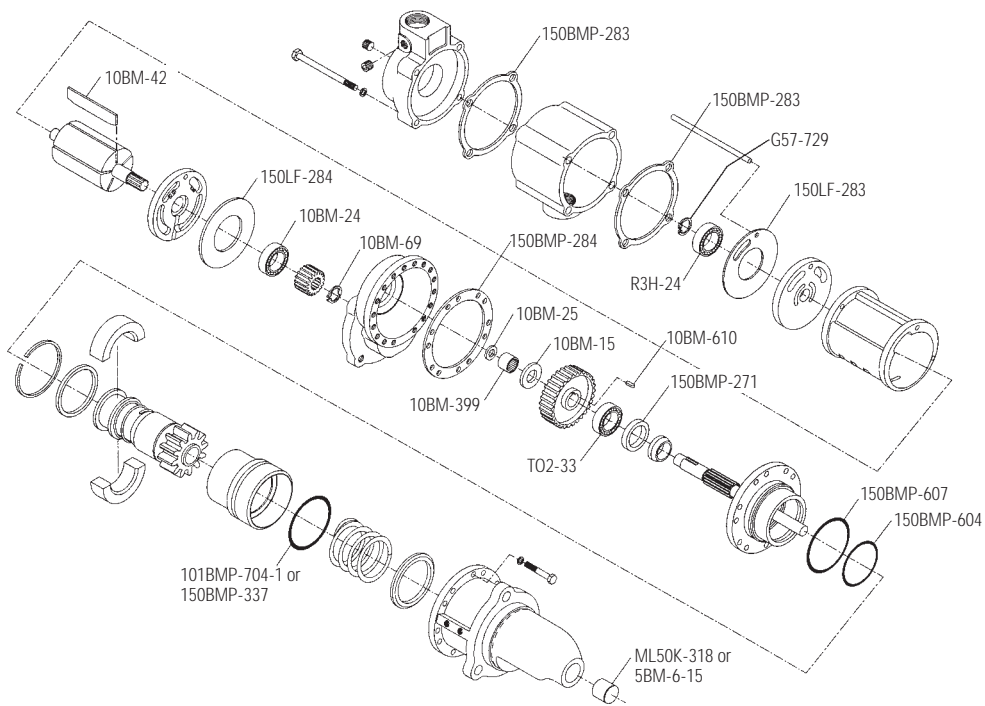

Exploded View of 150BM-TK2 Part Location



150BM-TK2 Parts



150LF-TK1 Parts

