



48393391
Edition 01
April 2012

Air Starters for Internal Combustion Engines

SS100 Series

Parts Information



Save These Instructions

 **Ingersoll Rand**

SS100 Starter - Cross Sectional View

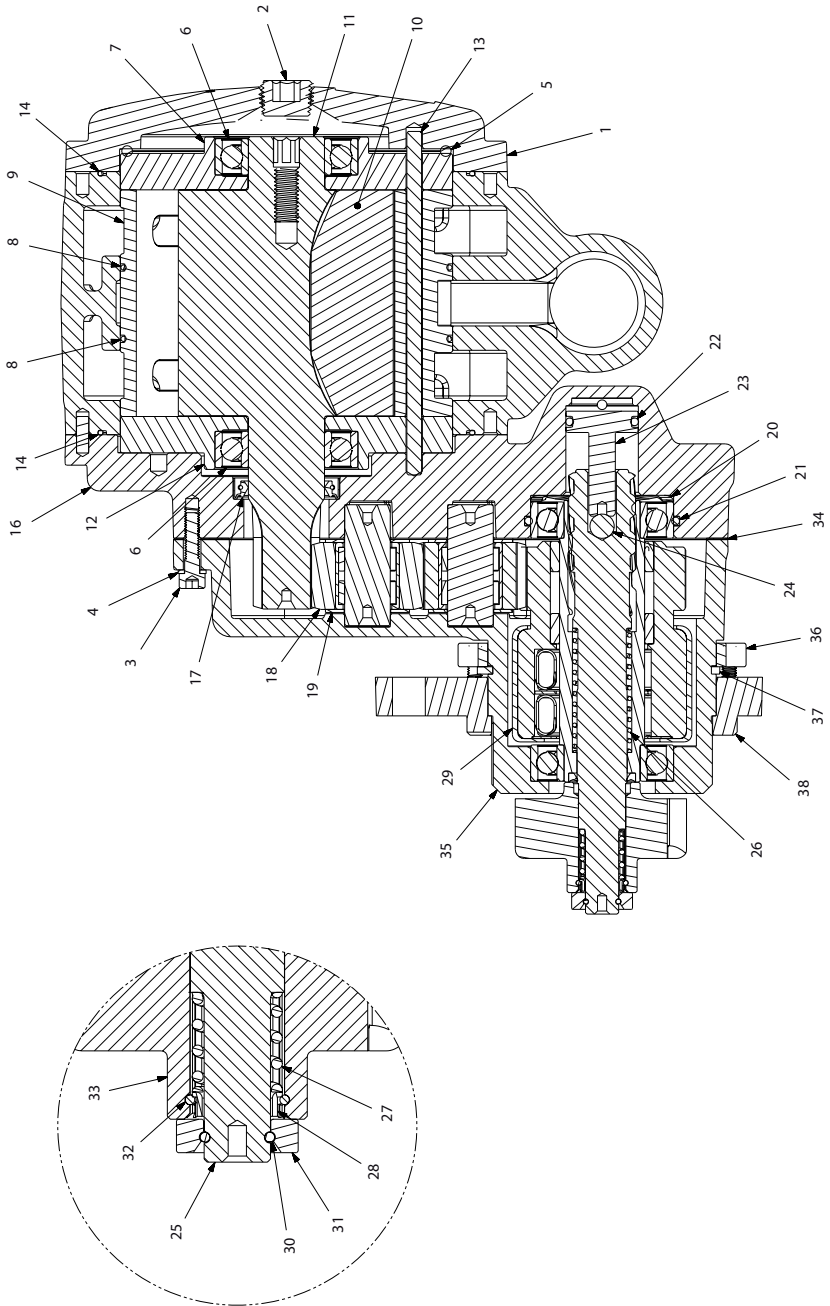

(Dwg. 48402374 SH1)

SS100 Starter - Exploded View

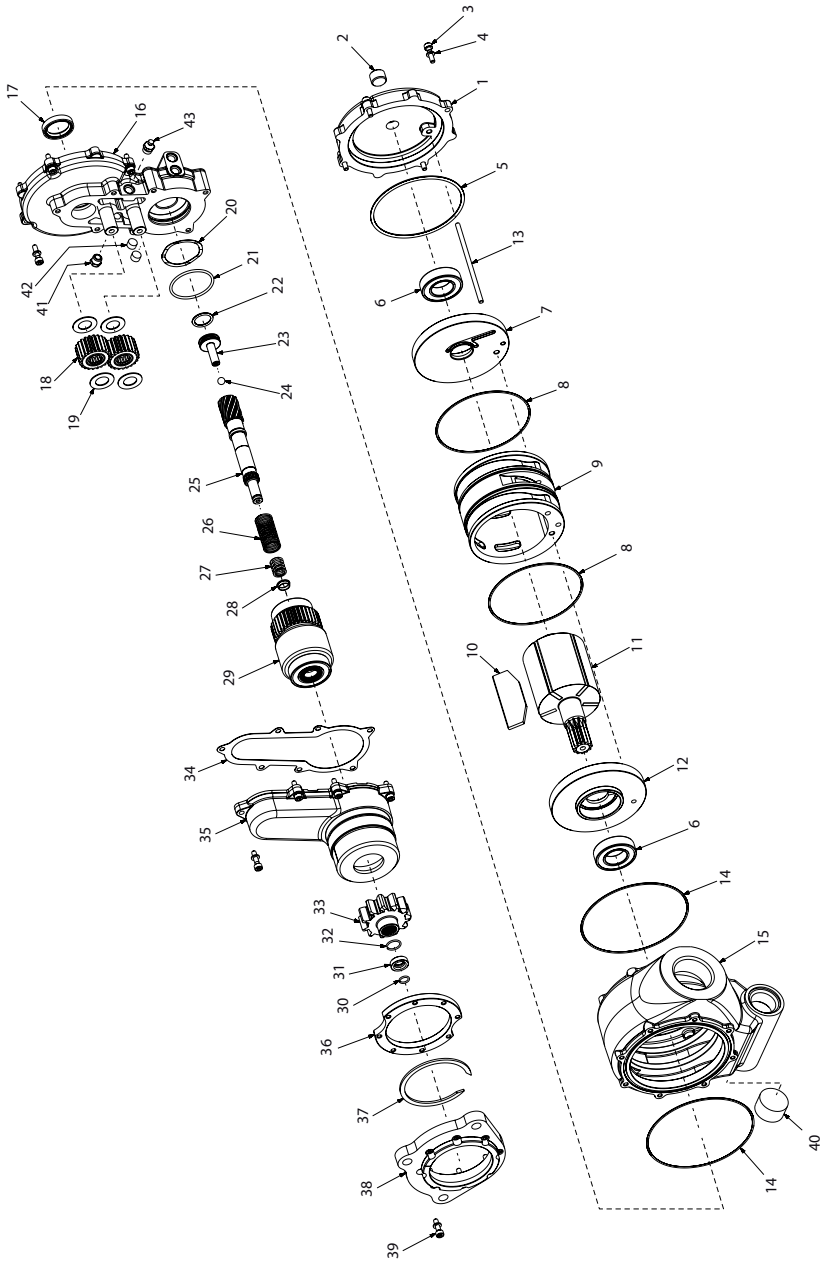

(Dwg. 48402374 SH2)

SS100 Starter - Parts List

Item	Part Description	Part Number	Item	Part Description	Part Number
1	Motor Cover	SS100-102	24	Ball	45612595
2	Pipe plug 3/8" NPT	HSPPS-3	25	Drive shaft	-
3	Cap screw M5-0.8x20 (15)	45641701	26	Return spring	-
4	Split lock washer M5 (23)	500M5C11	27	Pinion spring	-
5	O-ring	95086641	28	Spring collar	-
6	Motor bearing (2)	95976379	29	Clutch	-
7	Rear endplate	SS100-12	30	Collar retaining ring	-
8	Cylinder o-ring (2)	SS800-152	31	Pinion collar	-
9	Cylinder	SS100-3	32	Pinion retaining ring	-
10	Vane Pack	-	33	Pinion	See pinion chart
11	Rotor	SS100-53	34	Gasket	SS100-223
12	Front endplate	SS100-11	35	Drive housing	SS100-300
13	Motor dowel	SS100-98	36	Flange ring	SS100-337
14	Motor housing o-ring (2)	95427373	37	Retaining ring	48384192
15	Motor Housing	SS100-40	38	Flange	See flange chart
16	Intermediate housing assy	SS100-A37	39	Cap screw M5-0.8x18 (8)	47128426
17	Shaft seal	47100003		Cap screw M5-0.8x30 (8) (SAE 04 flange)	96759139
18	Gear assy (2)	SS100-A9	40	Pipe plug 1" NPT	Y227-7-L
19	Thrust washer (4)	211M19S11		Vent	CL250K-188
20	Wave spring	47124128	41		
21	Drive o-ring	Y325-133	42	Pipe plug 1/8" NPT (2)	Y227-2-L
22	Piston o-ring	Y325-116	43	Grease fitting 1/8" NPT	95201547
23	Engagement piston	SS100-20			

Description of Part	Part Number
Gear Kit (includes items 18, 19)	SS100-GK1
Tune up Kit (includes items 5, 6, 8, 10, 13, 14, 17)	SS100-TK1
Drive Housing Seal Kit (includes items 21, 22, 34)	SS100-TK2
Drive Kit (includes items 24, 25, 26, 27, 28, 29, 30, 31, 32)	SS100-K299
Pinion Hardware Kit (includes items 27, 28, 30, 31, 32)	SS100-299-18

Flange Chart

Flange Code (See model number)	Flange Part Number	Flange Kit Part Number*
01	SS100-301-01	SS100-K301-01
03	SS100-301-03	SS100-K301-03
04	SS100-301-04	SS100-K301-04
GM	SS100-301-GM	SS100-K301-GM

*Includes hardware.

www.ingersollrandproducts.com

© 2012 *Ingersoll Rand* Company

