



Accessories Index By Description

Accessory Description	IR Part #	Page Number
Relay Valves	SRV100 SRV125 SRV125T SRV150 SRV150SS SRV150-TK3	J-3 – J-4
Solenoid Control Valves	150BMP-1051B 150BMP-2451B 150BMP-6451B 150BMP-A1051C 150BMP-B2451	J-5
Angle Mounting Bracket		
Solenoid Control Valves	ST400-A339M ST400-C339 ST400-K619	J-6
ST400 Repair Kit		
Push Button Control Valves	SMB-618 SMB-G618 SMB-619 SMB-620	J-7
White Push Button Replacement Black Push Button Replacement		
Air Strainers	ST900-267-16 ST900-267-24 ST900-267-32 ST900-267-64	J-8 – J-9
Mufflers	3BM-WM07 3BM-A674 150BM-A674 SS350-A674 ST500-674 SS800-A674	J-10
Regulators	NR-24-8 NR24-TK1	J-11 – J-12
NR-24-8 Tune Up Kit		
In-Line Lubricators	NL-8-8 NL-24-8	J-13 – J-14
One-Shot Lubricators	HDL2 HDL3 HDL2-TK1 HDL3-TK1	J-15 J-15 J-15
HDL2 Replacement Kit HDL3 Replacement Kit		
Road Splash Deflectors	150BM-A735 SS350-A735 ST500-A735 SS800-A735	J-16
Exhaust Tube Kit	ST500-K740	J-16
Liquid Sealant	SMB-431 SMB-441	J-16
Check Valves	150BMP-1056 150BMP-1054 ST400-1056	J-17
Drain Valve	150BMP-1067	J-17
Gladhand Coupling	150BMP-1058	J-18
Pressure Gauges	150BMP-1064 150BMP-1064L	J-18

Accessories Index

Accessories Index By IR Part Number

IR Part #	Accessory Description	Page Number
150BM-A674	Muffler	J-10
150BM-A735	Road Splash Deflector	J-16
150BMP-1051B	Solenoid Control Valve	J-5
150BMP-1054	Check Valve	J-17
150BMP-1056	Check Valve	J-17
150BMP-1058	Gladhand Coupling	J-18
150BMP-1064	Pressure Gauge	J-18
150BMP-1064L	Pressure Gauge	J-18
150BMP-1067	Drain Valve	J-17
150BMP-2451B	Solenoid Control Valve	J-5
150BMP-6451B	Solenoid Control Valve	J-5
150BMP-A1051C	Solenoid Control Valve	J-5
150BMP-B2451	Solenoid Control Valve Angle Mounting Bracket	J-5
3BM-A674	Muffler	J-10
3BM-WM07	Muffler	J-10
HDL2	One-Shot Lubricator	J-15
HDL2-TK1	HDL2 Replacement Kit	J-15
HDL3	One-Shot Lubricator	J-15
HDL3-TK1	HDL3 Replacement Kit	J-15
NL-24-8	In-Line Lubricator	J-13 – J-14
NL-8-8	In-Line Lubricator	J-13 – J-14
NR-24-8	Regulators	J-11 – J-12
NR24-TK1	NR-24-8 Tune Up Kit	J-11 – J-12
SMB-431	Liquid Sealant	J-16
SMB-441	Liquid Sealant	J-16

IR Part #	Accessory Description	Page Number
SMB-618	Push Button Control Valve	J-7
SMB-619	White Push Button Replacement	J-7
SMB-620	Black Push Button Replacement	J-7
SMB-G618	Push Button Control Valve	J-7
SRV100	Relay Valve	J-3 – J-4
SRV125	Relay Valve	J-3 – J-4
SRV125F	Relay Valve	J-3 – J-4
SRV125T	Relay Valve	J-3 – J-4
SRV150	Relay Valve	J-3 – J-4
SRV150SS	Relay Valve	J-3 – J-4
SRV150-TK3	Relay Valve Tune Up Kit	J-3 – J-4
SS350-A674	Muffler	J-10
SS350-A735	Road Splash Deflector	J-17
SS800-A674	Muffler	J-10
SS800-A735	Road Splash Deflector	J-17
ST400-1056	Check Valve	J-17
ST400-A339M	Solenoid Control Valve	J-6
ST400-C339	Solenoid Control Valve	J-6
ST400-K619	Solenoid Control Valve ST400 Repair Kit	J-6
ST500-674	Muffler	J-10
ST500-A735	Road Splash Deflector	J-16
ST500-K740	Exhaust Tube Kit	J-16
ST900-267-16	Air Strainer	J-8 – J-9
ST900-267-24	Air Strainer	J-8 – J-9
ST900-267-32	Air Strainer	J-8 – J-9
ST900-267-64	Air Strainer	J-8 – J-9

Note: All dimensions shown are for reference only. Specifications subject to change without notice.

Relay Valves

Ingersoll-Rand Relay Valves provide immediate response to assure Air Starter disengagement and prevent damage to the pinion or flywheel ring gear. The aluminum die cast housing resists abrasion and corrosion while the stainless steel piston return spring will not rust from moisture in the air line.



SRV150



SRV150SS



SRV125F

Specifications

- Maximum Operating Pressure = 225 psi (15.5 bar)
- Operating Temperature Range = -20 to 250°F (-29 to 121°C)
- Flow/Pressure Drop shown on CSR-352: $C_v = 28.5$

Specifications

IR Part Number	NPT Size Inlet – Outlet	Weight – lb (kg)	Description
SRV100	1" – 1"	3.10 (1.41)	3BMG, 5BMG, SS175G Relay Valve
SRV125	1-1/4" – 1-1/4"	2.90 (1.32)	150BM, SS350G, 150T Relay Valve
SRV125T	1-1/4" – 1-1/4"	2.90 (1.32)	150BM, SS350G, 150T Relay Valve for Transportation
SRV150	1-1/2" – 1-1/2"	2.70 (1.22)	SS800, ST700, ST900, ST600 Relay Valve
SRV150SS	1-1/2" – 1-1/2"	7.15 (3.24)	SS800, ST700, ST900 Relay Valve for Natural Gas Use
SRV125F	1-1/4" Flanged	7.40 (3.36)	150T/150BM Transportation Relay/Solenoid Valve

Inlet Pressure vs. Pilot Pressure to Open

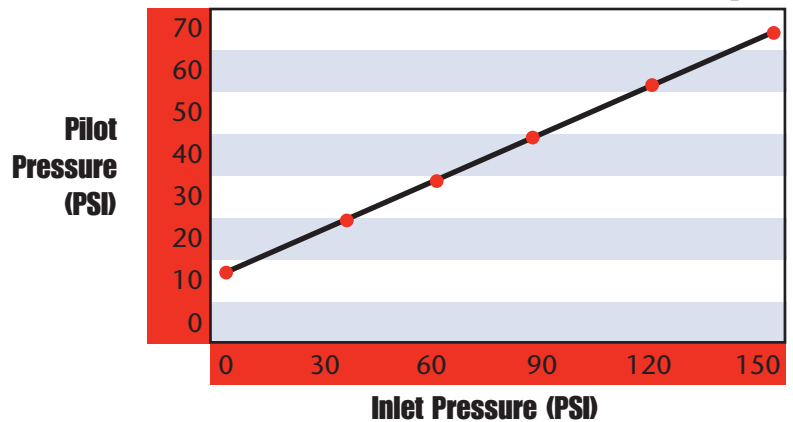

Relay Valves

Relay Valves DIMENSIONS

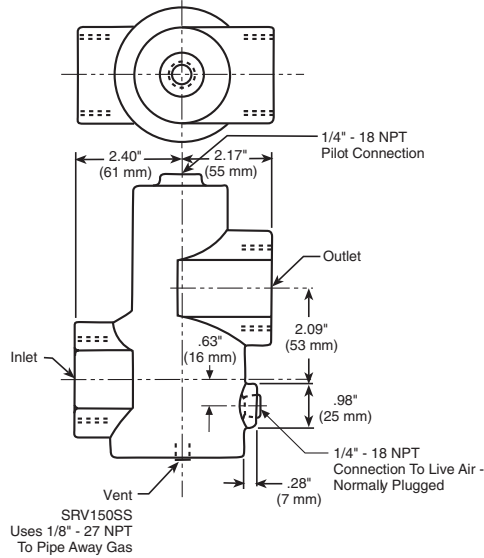
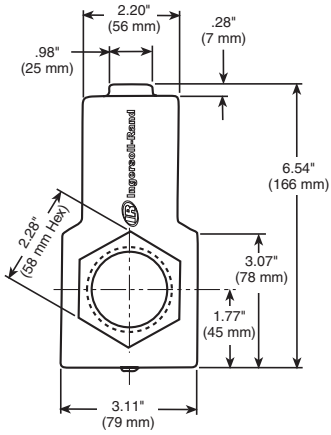

SRV150

SRV150SS
Uses 1/8" - 27 NPT
To Pipe Away Gas

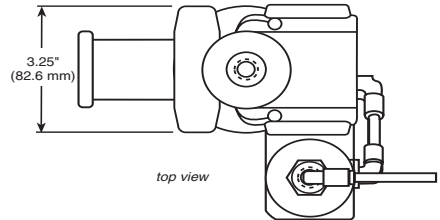
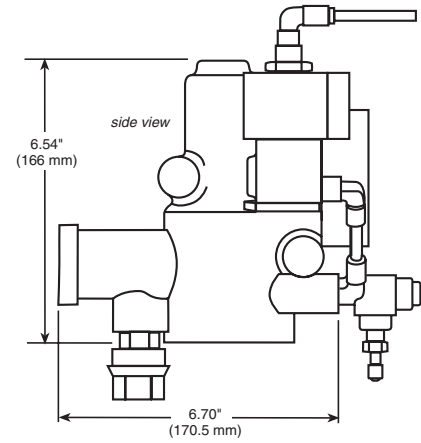

SRV125F

Relay Valves Genuine Ingersoll-Rand Replacement Kits

**Tune Up Kit
Part Number**

Description

SRV150-TK3

For use with SRV100, SRV125, SRV125T,
SRV150, and SRV150SS Relay Valves

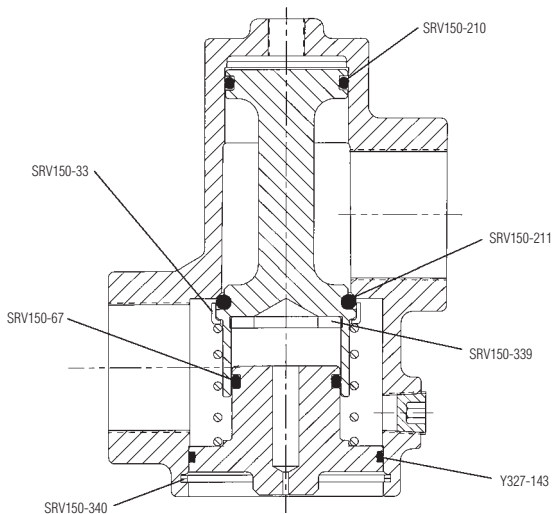

Cross-Section of SRV150-TK3 Part Location



SRV-TK3 Parts

Solenoid Control Valves

These DC electrically actuated valves are designed for pilot operation of the IR relay valve and are approved for applications affected by the U.S. Department of Transportation safety codes.

Specifications

- Valve Type: Three-way normally closed C_v Factor: 0.21
- Power Consumption: 25 watts
- Operating Pressure Range: 0 to 300 psig (0 to 20.7 bar)
- Proof Pressure: 375 psig (25.9 bar)
- Burst Pressure: 1250 psig (86.2 bar)
- Media: Air, Inert gases, water, light oils, natural gases
- Media Temperature: -4 to 392°F (-20° to 200°C)
- Ambient Temperature: -4 to 248°F (-20° to 120°C)
- Seal Material: Viton



150BMP-2451B

150BMP Solenoid Control Valves

IR Part Number	Thread Size Inlet - Outlet	Voltage (DC)	Weight lb (kg)	Description
150BMP-1051B*	1/4" - 1/4"	12 volt	1.95 (.88)	24" (61 cm) Long wire leads
150BMP-2451B*	1/4" - 1/4"	24 volt	1.95 (.88)	24" (61 cm) Long wire leads
150BMP-6451*	1/4" - 1/4"	64 volt	1.95 (.88)	24" (61 cm) Long wire leads
150BMP-A1051C*	1/4" - 1/4"	12 volt	1.95 (.88)	Pioneer Connector Lead

* Can be mounted on 150BMP-B2451 elbow bracket.

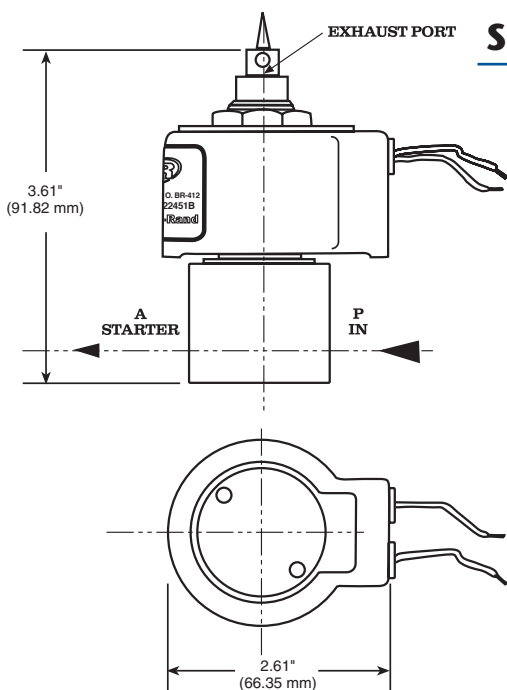

Solenoid Control Valve & Bracket DIMENSIONS

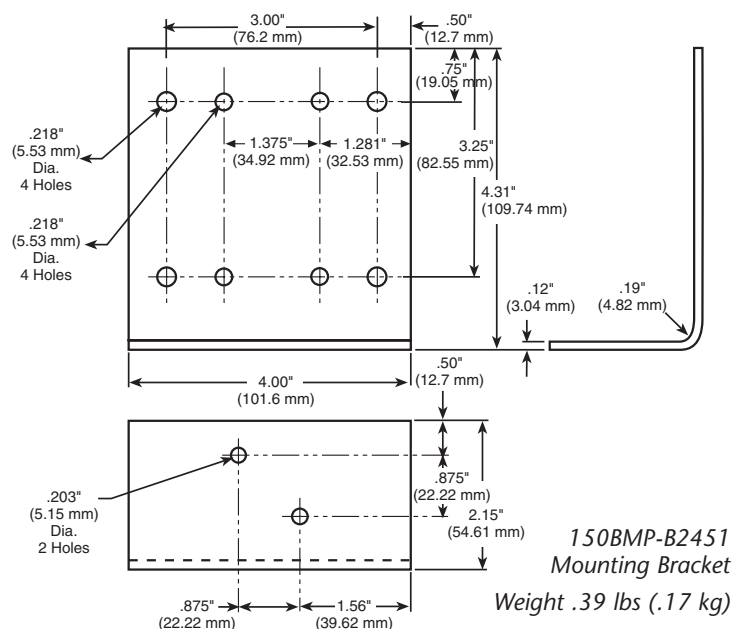

Solenoid Control Valves

Specifications

- Rated Operating Pressure: 150 psig
- Rated Operating Voltage: 12-24 VDC
- Rated Current Draw: 750 mA

ST400 Solenoid Control Valves

IR Part Number	Inlet - Outlet	Weight lb (kg)	Description
ST400-A339M	1" - 1" Flange Style	4.5 (2.04)	Manual Control Valve; must be coupled to Solenoid or Push Button Valve
ST400-C339	1" - 1" Flange Style	2.96 (1.34)	Relay Valve with top mounted Solenoid Valve
ST400-K619	N/A	.30 (.13)	ST400-A339M Repair Kit

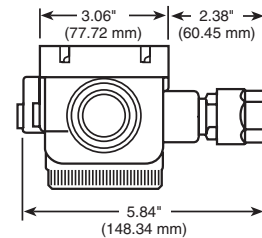
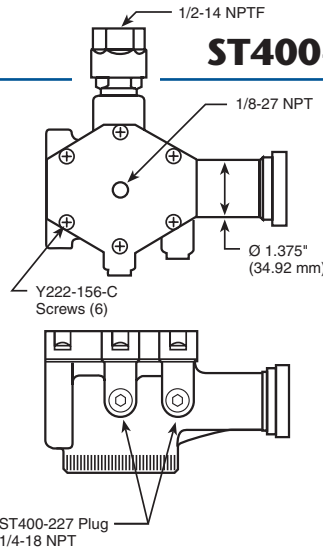
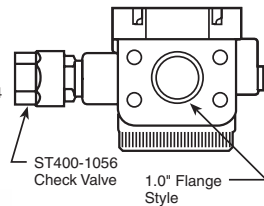
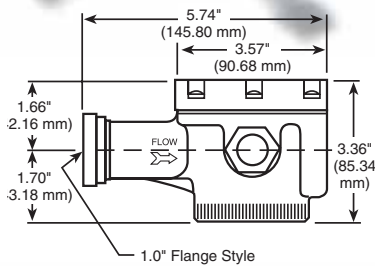

ST400-A339M DIMENSIONS

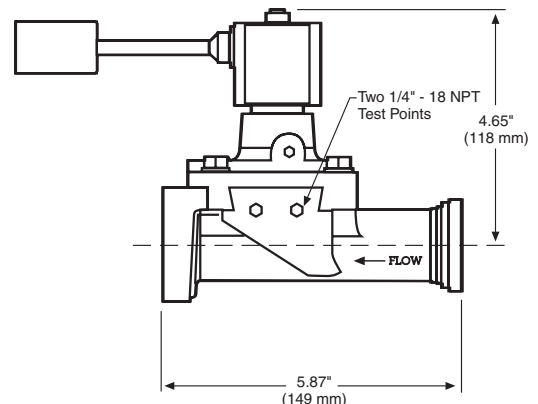
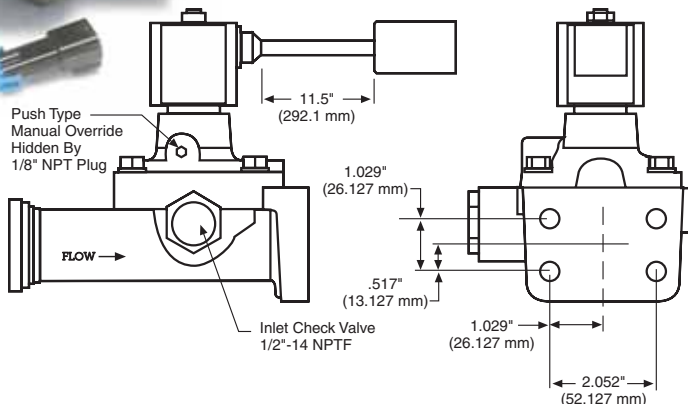

ST400-C339 DIMENSIONS

Air Strainers

IR strainers are used in the air line to assure long starter life where air or gas is contaminated. The strainer screens the starter air utilizing a 300-mesh element reinforced on two sides by a 20-mesh internal stainless steel screen to ensure air integrity.

Specifications

- Maximum Working Pressure:

Saturated Steam	Water, Oil, Gas	Compressed Air
250 psi @ 400°F	400 psi @ 150°F	500 psi @ 150°F
15.5 bar @ 204°C	27.6 bar @ 66°C	34.4 bar @ 66°C



ST900-267-16
Air Strainer



ST900-266-16
Strainer Element

ST900 Air Strainers

IR Part Number	Thread Size Inlet – Outlet (NPT)	Weight lb (kg)	IR Strainer Element Replacement Part #	Description
ST900-267-16	1" – 1"	3.00 (1.36)	ST900-266-16	3BMG, 5BMG, SS175G Strainer
ST900-267-24	1-1/2" – 1-1/2"	8.00 (3.63)	ST900-266-24	150BM, SS350G, 150T, ST400 Strainer
ST900-267-32	2" – 2"	12.50 (5.67)	ST900-266-32	SS800, ST700, ST900, ST600 Strainer
ST900-267-64	4" – 4"	60 (27.24)	ST900-266-64	SS800, ST700, ST900, ST600 Strainer

Air Strainers

Air Strainers DIMENSIONS

IR Part Number	Dim. A in. (mm)	Dim. B in. (mm)	Dim. C in. (mm)
ST900-267-16	4.00 (101.4)	3.25 (82.6)	2.62 (66.5)
ST900-267-24	5.75 (146.1)	5.00 (127.0)	3.87 (98.3)
ST900-267-32	7.00 (177.8)	6.125 (155.6)	4.75 (120.7)
ST900-267-64	13.50 (342.9)	13.00 (330.2)	8.25 (209.6)

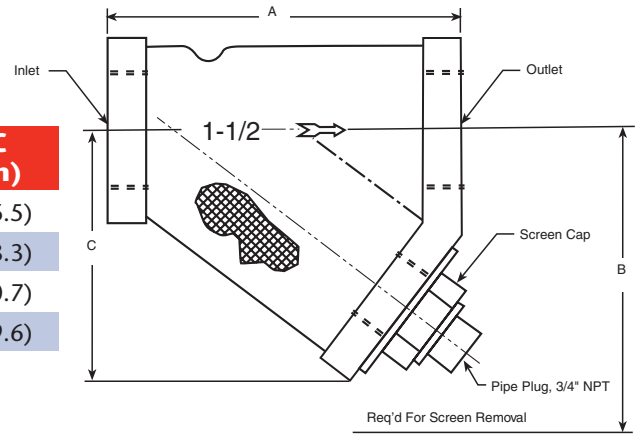

ST900-267-16 (1" Strainer) Pressure Drop at 900 SCFM

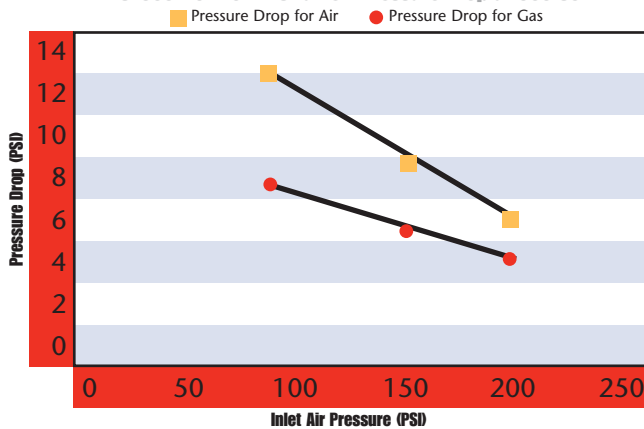

ST900-267-24 (1-1/2" Strainer) Pressure Drop at 1700 SCFM

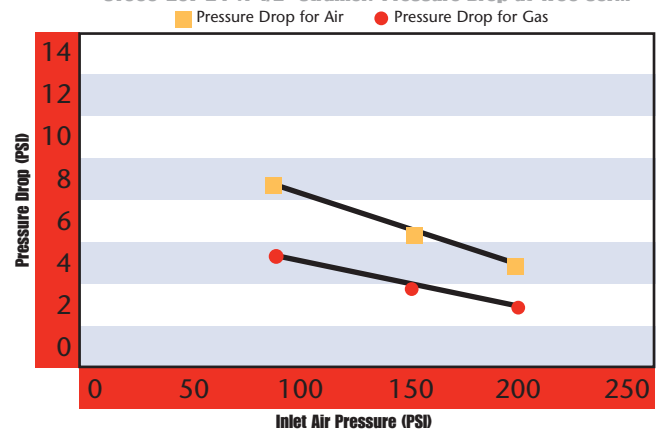

ST900-267-32 (2" Strainer) Pressure Drop at 3400 SCFM

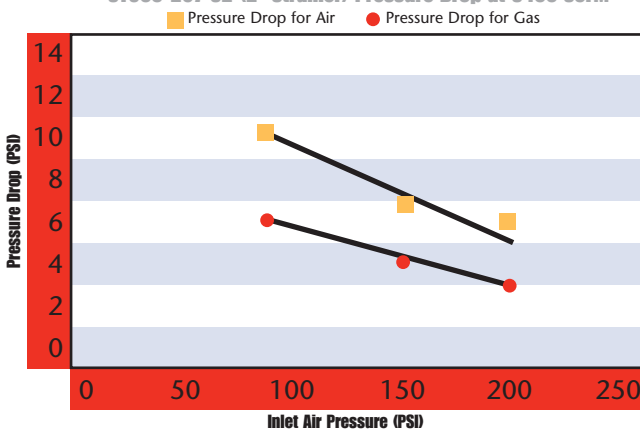

Mufflers

IR mufflers are designed to effectively limit starting noise levels.

Features

- Low back pressure provides minimal power loss for full starter power.
- Effective sound attenuation for low noise level.
- Non-freezing for reliable operation.
- Self-cleaning to eliminate clogging and ensure longer life while reducing maintenance time.
- Capable of direct or remote mounting for flexibility of application.

Muffler DIMENSIONS

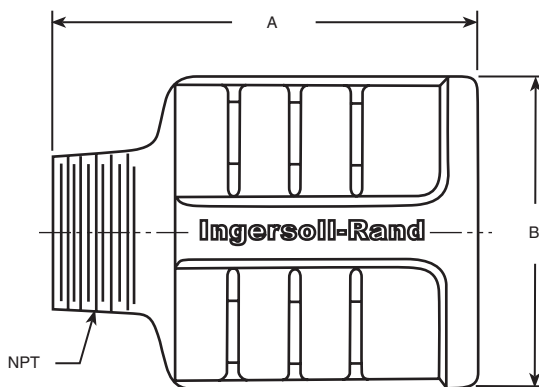

Specifications

IR Part Number	NPT Size	Dim. A in (mm)	Dim. B in (mm)	Weight lb (kg)	For Model Series
3BM-WM07	3/4"	7.18 (182.37)	2.22 (56.37)	.83 (0.38)	3BM, 5BM (Older Housing)
3BM-A674	1"	8.66 (219.96)	3.85 (97.79)	1.19 (0.54)	3BM, 5BM (New Housing)
150BM-A674	1-1/4"	4.21 (106.9)	3.34 (84.8)	1.50 (0.68)	150BM, SS175
SS350-A674	1-1/2"	4.56 (115.8)	3.31 (84.1)	1.13 (0.50)	SS350
ST500-674	2"	4.82 (122.3)	2.74 (69.6)	1.20 (0.54)	150T, ST500
SS800-A674	2-1/2"	6.66 (169.21)	4.75 (120.77)	3.35 (1.52)	SS800



3BM-WM07



3BM-A674



150BM-A674



SS350-A674



ST500-674



SS800-A674

Regulators

Rated Operating Conditions

- Inlet Pressure: 10 to 450 psig (0.7 to 31 bar)
- Maximum Outlet Pressure: 250 psig (17.2 bar)
- Temperature: 0° to 175°F (-18° to 79°C)
- With dewpoint less than air temperature below 35°F (2°C)
- Air Consumption: 2200 scfm @ 150 psi

Specifications

- Fluid: Compressed Air
- Type: Standard: Relieving
Optional: Nonrelieving
- Ports: Main: 1-1/2" or 2" PTF
Gauge: 1/4" PTF
Exhaust (Relieving models only): 3/4" PTF
- Outlet Pressure Adjustment Ranges*:
Standard: 5 to 125 psig (.3 to 8.6 bar)
Optional: 2 to 50 psig (.1 to 3.5 bar)
Optional: 10 to 250 psig (.7 to 17.2 bar)
- Threads: Use SMB-441 sealant on threads of air line fittings. Apply sealant evenly to threads only. Excessive sealant may interfere with valve operation.

* Outlet pressure adjustment ranges are not minimum or maximum outlet pressure limits. Regulators can be adjusted to zero psig outlet pressure and, generally, to pressures in excess of those specified. The use of these regulators to control pressures outside of the specified ranges is not recommended.



NR-24-8 Pilot Operated Regulator with Integral Pilot

Regulators

IR Part Number	Description
NR-24-8	Pilot Operated Regulator with Integral Pilot
NR24-TK1	NR-24-8 Tune Up Kit

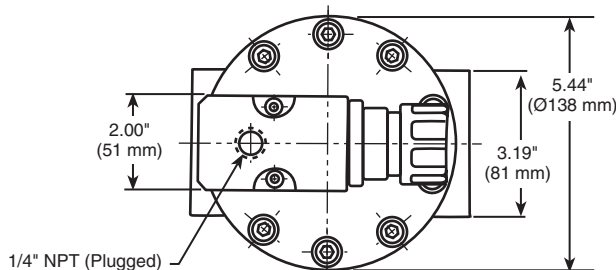

NR-24-8 DIMENSIONS

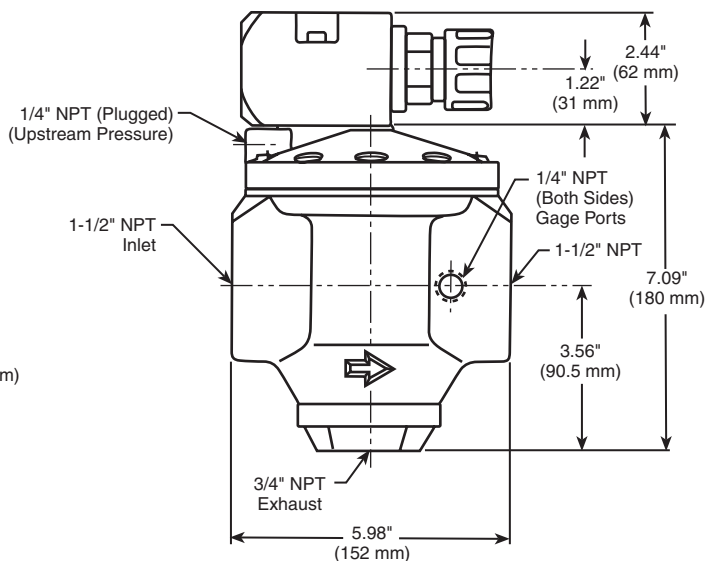

Regulators

Pilot Regulator Constant Bleed Feature

The constant bleed feature helps to minimize drop in the outlet pressure when a flow demand is initially placed on the regulator. A very small amount of pilot outlet air continuously escapes to atmosphere. This keeps the pilot valve slightly open to replace the air lost to atmosphere through the constant bleed. Since the valve is always partially open, the pressure drop is minimized when demand is initially increased from no flow to some higher flow. This constant escape of air from the pilot regulator vent is normal and does not indicate a faulty regulator.

Installation

1. Install a compressed air filter upstream of regulator.
2. In systems with a cyclic demand, install regulator upstream of cycling control valves.
3. System piping should be same size as regulator ports.
4. Install regulator as close as possible to the device being serviced. Regulator can be installed at any angle.
5. Connect piping to proper ports using pipe thread sealant on male threads only. Do not allow sealant to enter interior of regulator. Air flow must be in same direction as arrow on slave regulator body.
6. If desired, connect an outlet pressure gauge to one of the gauge ports. Gauge ports can also be used as additional outlets. Plug unused gauge ports.
7. To reduce noise and protect internal ports, install a muffler (part number M8006A) in the exhaust port (marked "EXH") of relieving type regulators.

Adjustment

1. Before turning on system pressure, turn pilot regulator adjusting knob counterclockwise until all load is removed from regulating spring.
2. Turn on system pressure.
3. Turn pilot regulator adjusting knob clockwise until the desired outlet pressure is reached.
4. To avoid minor readjustment after making a change in pressure setting, always approach the desired pressure from a lower pressure. When reducing from a higher to a lower setting, first reduce to some pressure less than that desired, then bring up to the desired pressure.
5. Push locking on adjusting knob downward to lock pressure setting. To release, pull locking upward.

Warning

These regulators are intended for use in industrial compressed air systems only. Do not use these regulators where pressure or temperature can exceed rated operating conditions.

If outlet pressure in excess of the regulator pressure setting could cause downstream equipment to rupture or malfunction, install a pressure relief device downstream of the regulator. The relief pressure and flow capacity of the relief device must satisfy system requirements.

The accuracy of the indication of pressure gauges can change, both during shipment (despite care in packaging) and during the service life. If a pressure gauge is to be used with these products and if inaccurate indications may be hazardous to personal property, the gauge should be calibrated before initial installation and at regular intervals during use. For gauge standards refer to ANSI 840, 1-1974.

These products are not designed for use with fluids other than air, for nonindustrial applications, or for life support systems.

Installation Warning

Do not plug exhaust port in bottom plug of relieving type regulators, as the relief feature will become inoperative.

In-Line Lubricators

Specifications

- Reservoir: 1/2 Pint Metal
- Maximum Operating Temperature = 175°F (79°C)
- Maximum Operating Pressure = 250 psi (17.2 bar)
- $C_v = 26$
- Media: Air, Clean natural gas (See Circular Letter A-1077)
- Recommended Operating Flow Range at 100 psig (6.9 bar): 160 to 600 scfm (78 to 283 dm³/s)
- Recommended Lubricants: This lubricator will perform satisfactorily using misting type oils rated 150 to 200 SSU (Saybolt seconds) @ 110°F (38°C)
- Material Construction: Body = Aluminum
Reservoir = Steel
Sight-Feed Dome = Pyrex & Aluminum
Elastomers = Neoprene & Buna-N



NL-8-8



NL-24-8

Installation

- Air line piping should be same size as lubricator ports.
- Install lubricator vertically (sight-feed dome up) in air line downstream of filter and regulator as near as possible to the device being served. This lubricator may be installed upstream or downstream of directional control valves.
- Connect piping to proper ports using pipe thread sealant on male threads only. Do not allow sealant to enter interior of lubricator. Air flow must be in direction of arrow on side of body.
- Remove fill plug and fill reservoir with a good quality lubricant to 3/4" below bottom of threads on dipstick. Do not overfill.

Adjustment

- Adjust drip rate only when there is a constant rate of flow through the lubricator.
- Determine the average rate of air flow (scfm) through the lubricator, then adjust the needle valve using a 3/32" Allen Wrench to obtain the recommended drip rate (Drops/min). Turn needle valve counterclockwise to increase and clockwise to decrease the drip rate.
- Monitor the device being lubricated for a few days following initial adjustment. Readjust the drip rate if the oil delivery at the device appears either excessive or low.

Warning

These units must not be used where pressure or temperature may exceed maximum rated operating conditions. See specifications.

In lubrication applications, some oil mist may escape from the point of use into the surrounding atmosphere. Users are referred to OSHA safety and health standards for limiting oil mist contamination and utilization of protecting equipment.

In-Line Lubricators

Specifications

IR Part Number	Port Thread Size NPT Inlet - Outlet	Weight lb (kg)
NL-8-8	1/2" - 1/2"	1.70 (.77)
NL-24-8	1-1/2" - 1-1/2"	2.70 (.1.22)
NL24-TK1	N/A	.05 (.02)

NL-8-8 DIMENSIONS

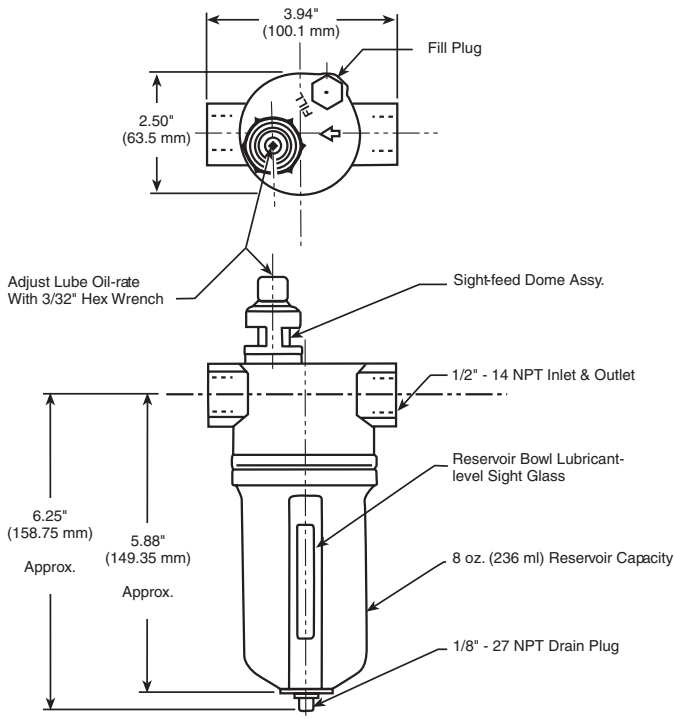

NL-24-8 DIMENSIONS

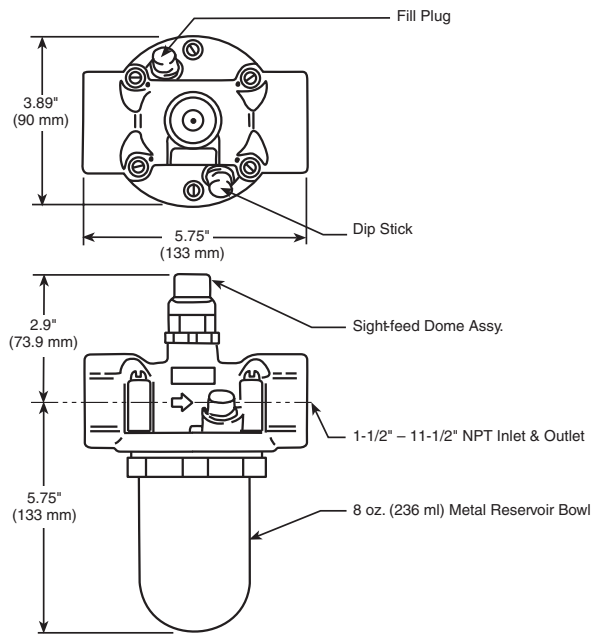

Recommended Drip Rate

Recommended Drip Rate Settings for Average Lubrication.

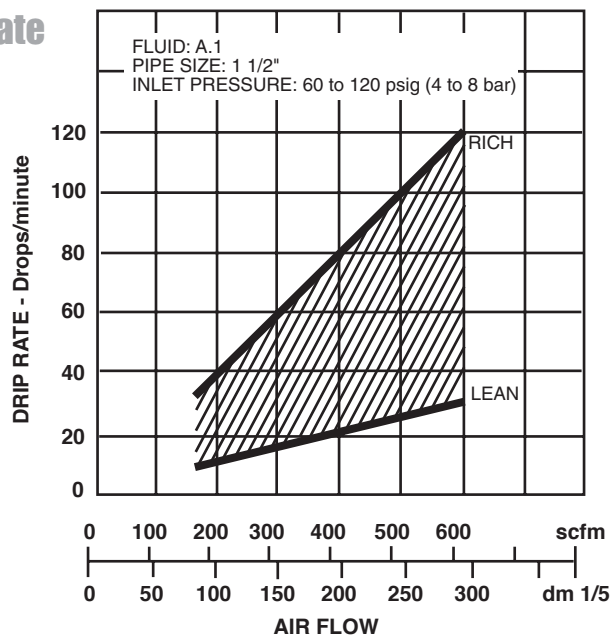

One-Shot Lubricators

These small, rugged one-shot lubrication devices dispense a controlled amount of lubricant each time the air starter is engaged. Attached directly to the starter, these lubricators are self-priming lubrication pumps, which can draw oil from as far away as 4 feet.

IR Part Numbers: HDL2 and HDL3

Specifications

- Oil inlet must be full of clean oil
- Operating Air Pressure Range: 40 to 250 psi (2.8 to 17.2 bar)
- Operating Temperature: -30°F to 250°F (-34°C to 121°C)
- Operating Lube Pressure: 0-50 psi
- Lubrication Rate: HDL2 = 1.3 cc HDL3 = 0.4 cc
- All-Viton Seals



HDL2

HDL2/HDL3 DIMENSIONS

IR Part Number	Dim. A in. (mm)	Dim. B in. (mm)
HDL2	2.99 (76)	3.55 (90.2)
HDL3	3.11 (79)	3.67 (93.2)

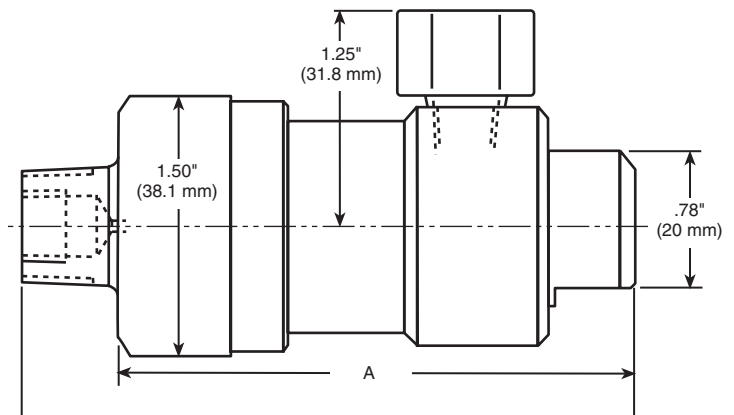

One-Shot Lubricators Genuine Ingersoll-Rand Replacement Kits

Tune Up Kit Part Number	Description
HDL2-TK1	HDL2 Tune Up Kit
HDL3-TK1	HDL3 Tune Up Kit



HDL2-TK1 Parts



HDL3-TK1 Parts

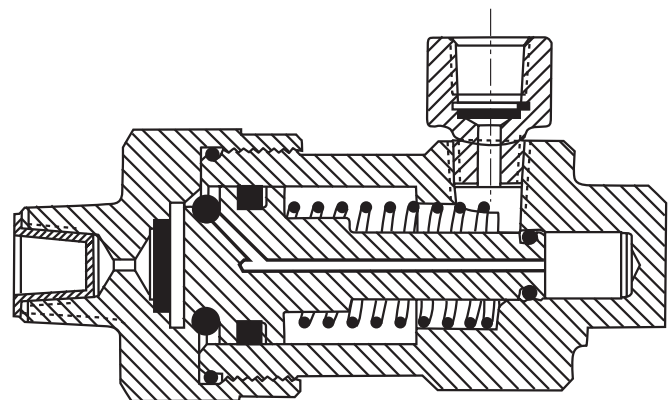

HDL2/HDL3 Cross Section

Road Splash Deflectors

Constructed of all corrosion-resistant materials, these road splash deflectors are designed to prevent contamination from entering the exhaust port of the starter. Used in applications where a muffler is not required, they allow maximum exhaust air flow for greater starting power and efficiency.

150BM-A735 DIMENSIONS

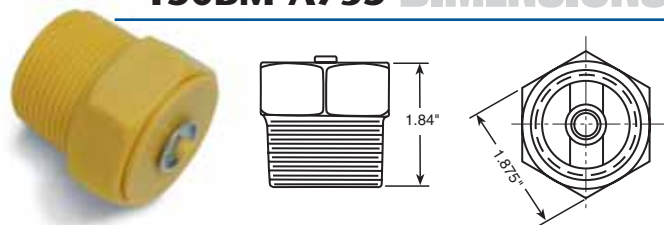

SS350/ST500/SS800 DIMENSIONS

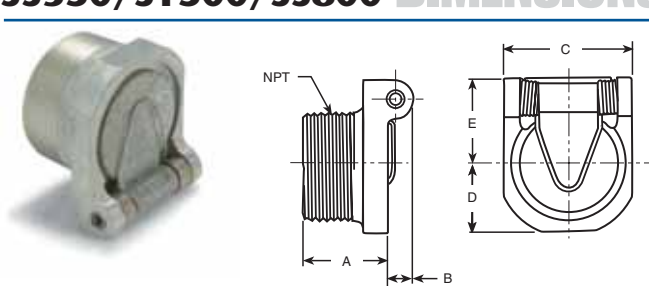

IR Part Number	NPT Size in (mm)	Description	Weight lb (kg)	Dimensions — in (mm)				
				A	B	C	D	E
150BM-A735	1-1/4 (31.75)	150BM Splash Deflector	.12 (0.05)	—	—	—	—	—
SS350-A735	1-1/2" (38.10)	SS350 Splash Deflector	.29 (0.13)	1.40 (35.56)	0.40 (10.16)	2.00 (50.80)	1.00 (25.40)	1.30 (33.02)
ST500-A735	2" (50.80)	150T and ST500 Series Splash Deflector	.45 (0.20)	1.44 (36.50)	0.37 (9.50)	2.63 (66.80)	1.32 (33.60)	1.70 (43.20)
SS800-A735	2-1/2" (63.50)	SS800, SS660, & SM450 Series Splash Deflector	.61 (0.28)	1.90 (48.26)	0.40 (10.16)	3.00 (76.20)	1.50 (38.10)	1.75 (44.45)

Exhaust Tube Kit

IR Part Number	NPT Size in (mm)	Description
ST500-K740	2" (50.80)	150T & ST500 Duckbill & Clamp



Liquid Sealant

Liquid sealants should always be used to ensure an air-tight system for air and gas applications.

IR Part Number	Weight lb (kg)	Description
SMB-431	.18 lb (.08 kg)	50 cc "Plastic Gasket" For Gas Sealing
SMB-441	.03 lb (.01 kg)	50 cc Teflon® Sealant For Pipe Threads



© Teflon is a registered trademark of El DuPont de Nemours and Company.

Check Valves

The 150BMP-1056 is a brass-bodied check valve designed for use in receiver charging systems. It is particularly recommended for vehicular applications. The 150BMP-1054 is a combination check valve/pressure relief valve.

IR Part Number	Thread Size NPT	Weight lb (kg)	Description
150BMP-1056	1/2"	.37 lb (.16 kg)	Check Valve
150BMP-1054	3/4"	.10 lb (.04 kg)	Combination Pressure Relief / Check Valve
ST400-1056	3/4"	.37 lb (.16 kg)	Check Valve with O-Ring

150BMP-1056 ST400-1056 DIMENSIONS

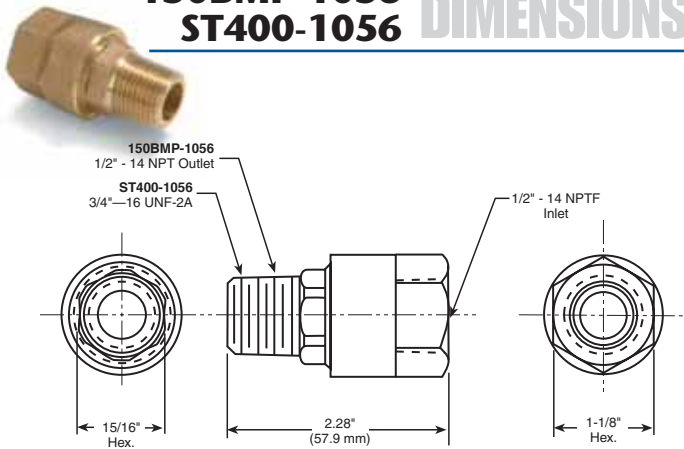

150BMP-1054 DIMENSIONS

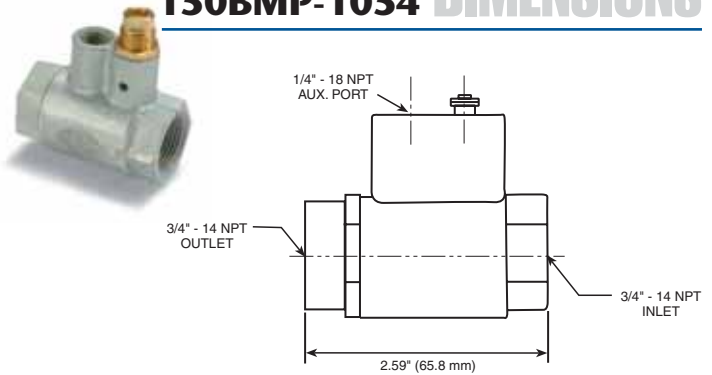

Drain Valve

Used to keep air supplies clean and free of water and other contaminants.

IR Part Number	Weight lb (kg)	Description
150BMP-1067	.100 lb (.04 kg)	1/2" NPT Connection



150BMP-1067 DIMENSIONS

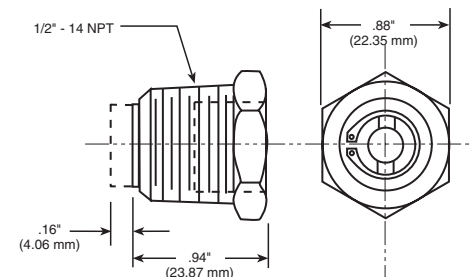

Gladhand Coupling

Should air pressure ever be lost, the gladhand makes it simple to pump up your system from any nearby truck.

Specifications

- Maximum Operating Pressure: 150 psi
- Maximum Operating Temperature: 200°F
- Weight: .49 lb (0.22 kg)



150BMP-1058

150BMP-1058 DIMENSIONS

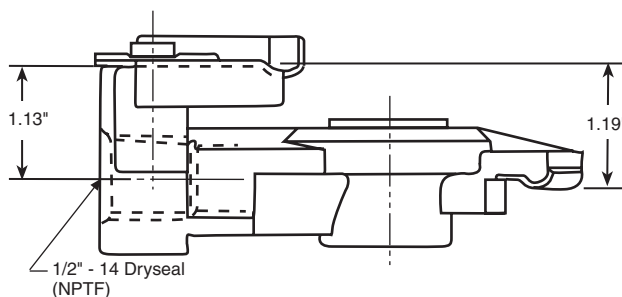
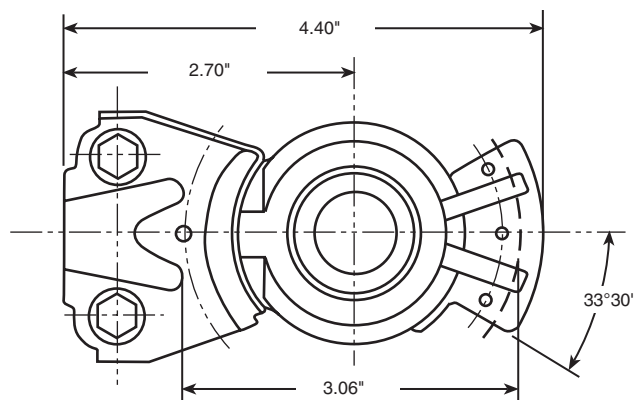

Pressure Gauges

With a large readout dial, the air pressure gauge assures the user that sufficient air pressure is available for starting before user shuts off engine.



150BMP-1064

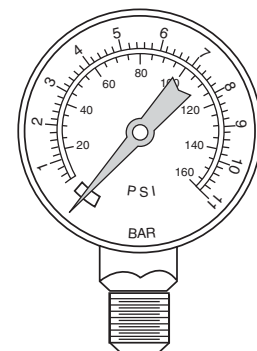

150BMP-1064L

Specifications

IR Part Number	150BMP-1064	150BMP-1064L	SRV125F-1064
Description	Dash Mount Gauge	Standard Industrial Gauge	Industrial Gauge
Weight - lb (kg)	0.3 (.14)	.16 (.07)	.16 (.07)
Pressure Range (PSI)	0 to 150	0 to 160	0 to 300
Dual Scale Dial	PSI and kPa	PSI and bar	PSI and bar
Diameter Size	2.25" (57.2 mm)	2" (50.8 mm)	2.71" (68.8 mm)
Connection	1/8" NPTF Male Connection on Back	1/4" - 18 NPT Male Connection Centered on Bottom	1/4" - 18 NPT Male Connection Centered on Bottom
Additional Features	5/8" Diameter Lamphole and 2 tighten screws on back	N/A	N/A

Note: Accuracy is +/- 2 degrees of full scale